

GENUINE CIGARETTE LIGHTER

INSTALLATION AND USER'S INSTRUCTIONS

Vehicle: MAZDA CX-5

Parts numbers: BBP3 66 250

Thank you for purchasing a genuine Mazda accessory.

Before removal and installation, be sure to thoroughly read these instructions.

Please read the contents of this booklet in order to properly install and use the cigarette lighter. Your safety depends on it.

Keep these instructions with your vehicle records for future reference.

Note:

- There are several **⚠WARNING** and **⚠CAUTION** sections in this booklet concerning safety when installing or removing the cigarette lighter. Always read and follow them in order to prevent injuries, accidents, and possible damage to the vehicle.

⚠ WARNING: Indicates a situation in which serious injury or death could result if the warning is ignored.

⚠ CAUTION: Indicates a situation in which bodily injury or damage to the vehicle could result if the caution is ignored.

- For areas indicating the tightening torque in this instruction manual, tighten to the specified torque using a torque wrench. For areas in which the tightening torque is indicated inside parentheses (), the tightening torque is indicated as a reference value, however tightening using a torque wrench is not necessary.
- Do not modify the cigarette lighter.
- Do not install the cigarette lighter in any way other than described in the following instructions.
- If in any doubt, please ask your Mazda dealer to install the accessory in order to prevent errors in installation.
- If you have any questions about the use of the accessory, ask your Mazda dealer for proper advice before using it.
- Mazda and its suppliers are not responsible for injuries, accidents, and damage to persons and property that arise from the failure of the dealer or installer to follow these instructions.
- To ensure safety and reliability of the work, installation, removal and disposal work by an Authorized Mazda Dealership is recommended.
- Be careful not to lose removed parts, and be sure that they are kept free from scratches, grease or other dirt.

To the dealer

Please turn over these instructions to the customer after installation.

To the customer

- Keep these instructions after installation. The instructions may be necessary for installing other optional parts or removal of this accessory.
- Should the vehicle or this accessory be resold, always leave these instructions with it for the next owner.

1. PARTS

▼ INSTALLATION VIEW

NOTE:

- The directions are given for left-hand drive vehicles, however, the directions for right-hand drive vehicles are the same.

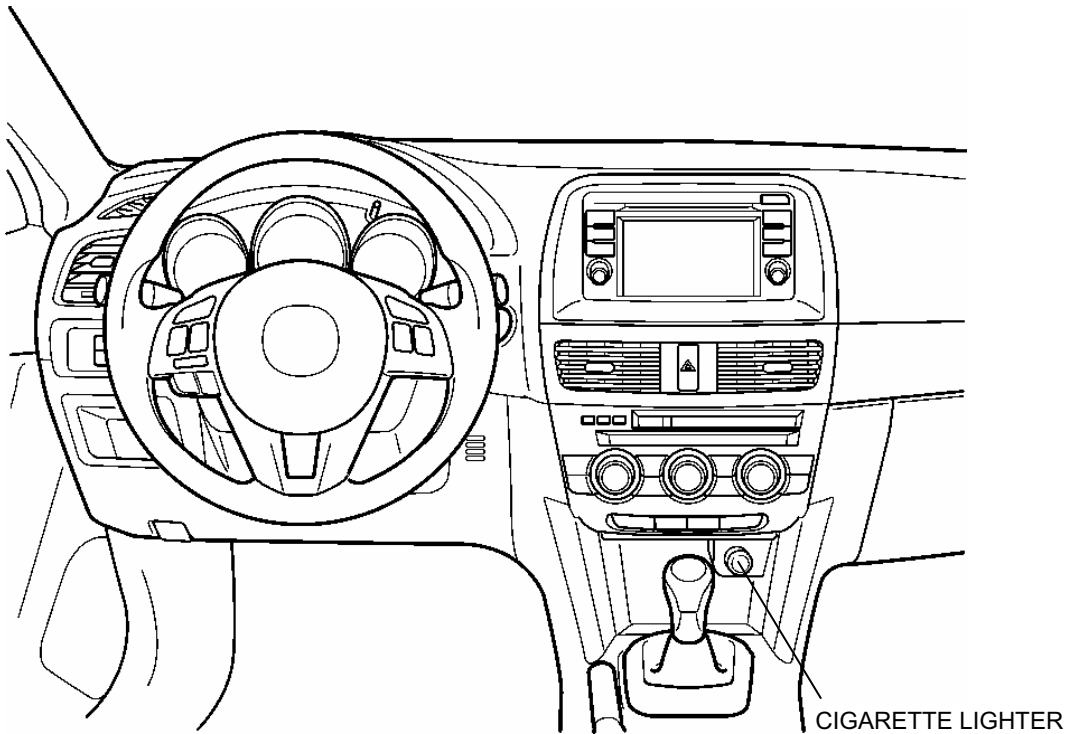



⚠ WARNING

- Do not install this accessory in any location other than the specified location as it may cause a fire.

▼ PARTS LIST

NOTE:

- Before installation, verify that the kit includes all the following parts and that they are free of dirt, scratches, or damage.



Part	Part name	Qty.	Part	Part name	Qty.	Part	Part name	Qty.
	Cigarette lighter plug	1		Ring	1		Socket	1

2. BEFORE INSTALLATION

▼ REQUIRED TOOLS

☆Flathead screwdriver wrapped with tape ☆Phillips screwdriver ☆Fastener remover

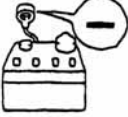
⚠ WARNING

When the negative battery cable is connected during operation, it may cause electric shock or other personal injuries. Disconnect the negative battery cable before removal/installation.	Do not pull the harness With excessive force. Doing so can cause a breakage or a short-related accident, as well as an electrical short or fire.	When connecting/disconnecting connectors, grasp the connectors, not the wires. Otherwise a short, an accident from poor contact or fire may occur.
		

⚠ WARNING

- When removing/installing the parts, park the vehicle on level ground and apply the side brake securely. Be sure to turn the ignition switch off, otherwise the vehicle can move, causing personal injury or vehicle damage.

⚠ CAUTION

- Wrap a flathead screwdriver or fastener remover with protective tape to prevent scratches to the vehicle.

Note

- When the negative battery cable is removed, the clock, radio, trip meters and other memories will be erased. Before performing work, record the content of the memory.
- Refer to the Workshop Manual for removal and installation of vehicle parts. Not following the procedures for removal/installation in the Workshop Manual could result in an accident or vehicle malfunction.

3. PARTS REMOVAL

Negative battery cable disconnection

1. Set the selector lever to P range. (ATX vehicles only)

⚠ WARNING

When removing/installing the parts, park the vehicle on level ground and apply the side brake securely. Be sure to turn the ignition switch off, otherwise the vehicle can move, causing personal injury or vehicle damage.

2. Disconnect the negative battery cable and wrap tape around it to insulate.

⚠ WARNING

- When the negative battery cable is connected during operation, it may cause electric shock or other personal injuries. Disconnect the negative battery cable before removal/installation.

Decoration panel removal

⚠ CAUTION

- Affix protective tape to the position shown in the figure.

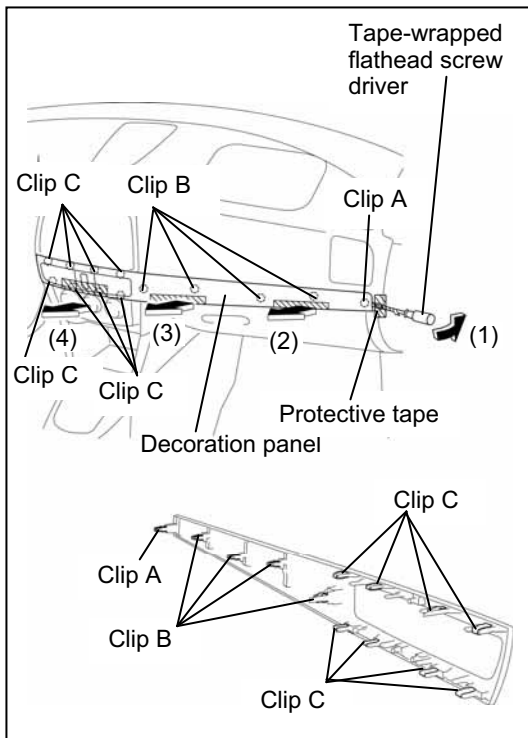

1. Insert a tape-wrapped flathead screwdriver in the position indicated by the arrow (1) in the figure and detach clip A.
2. Take the shaded area shown in the figure, and remove the decoration panel in the direction of the arrow in the order of (2), (3), (4) while detaching the clip B, clip C.
3. Disconnect the hazard switch connector.

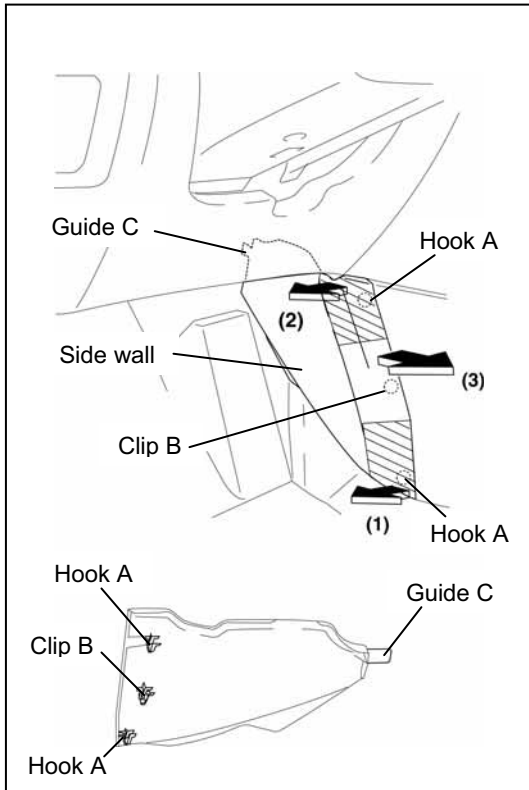

Side wall removal

1. Pull the side wall in the direction of the arrow in the order of (1), (2) and remove it while detaching the hook A and clip B.
2. Pull the side wall in the direction of the arrow (3) and remove it while detaching the guide C.

⚠ CAUTION

- If the hook A and clip B is removed forcefully, guide C may be damaged. Carefully remove the hook A and clip B so as not to damage guide C.

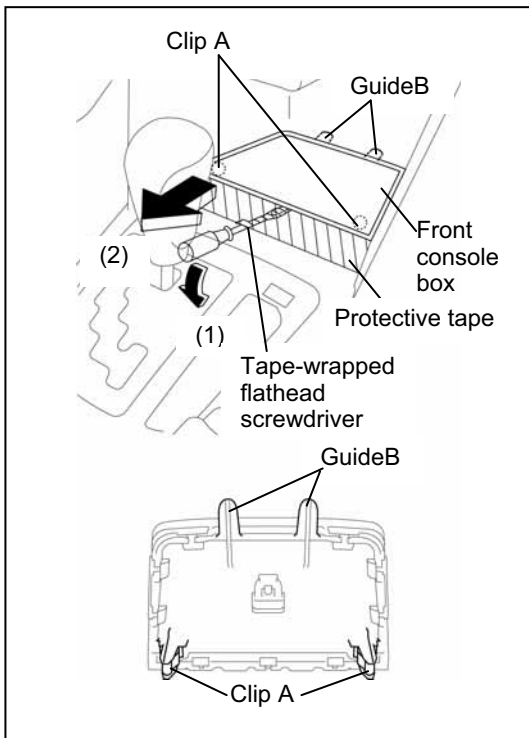

Front console box removal

⚠ CAUTION

- Affix protective tape to the position shown in the figure.

1. Insert a tape-wrapped flathead screwdriver in the position indicated by the arrow (1) in the figure and detach clip A.
2. Pull the front console box in the direction of the arrow (2) and remove it while detaching the guide B.

Shift panel (ATX) removal

1. Shift lever to neutral position.
2. Remove the selector lever knob.
3. Take the shaded area shown in the figure, and remove the shift panel in the direction of the arrow in the order of (1), (2) while detaching the clip A, hook B.
4. Disconnect the connector.

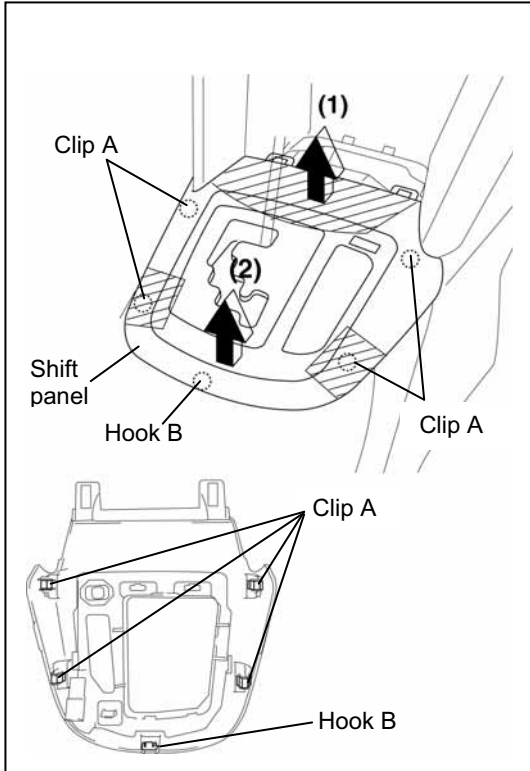

Shift panel (MTX) removal

1. Remove the shift lever knob.
2. Take the shaded area shown in the figure, and remove the shift panel in the direction of the arrow in the order of (1), (2) while detaching the clip A, pin B, hook C.

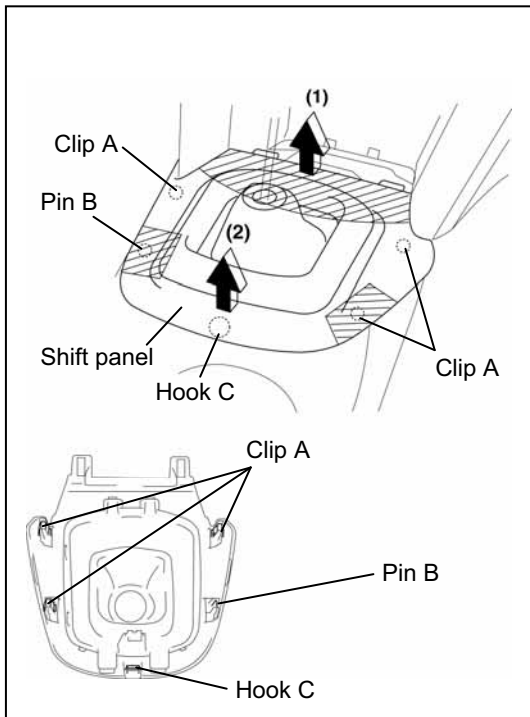

Upper panel removal

1. Open the console lid.
2. Take the shaded area shown in the figure, and remove the upper panel in the direction of the arrow in the order of (1), (2) while detaching the clip A, pin B, hook C.

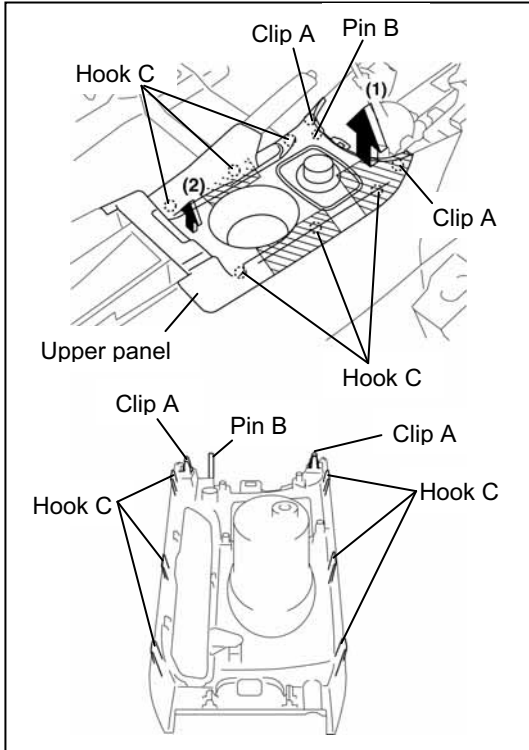

3. Remove the clip D.
4. Disconnect the command switch connector.

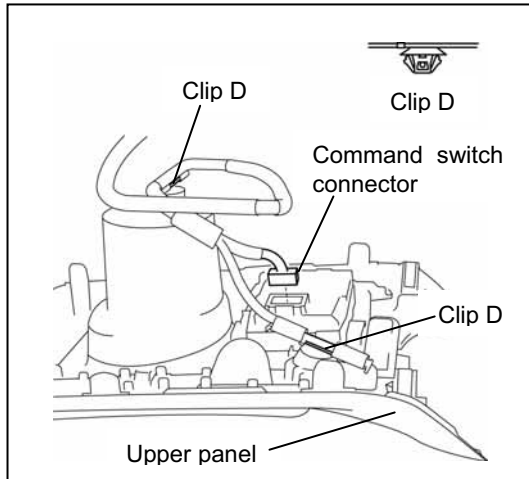

Rear console removal

1. Remove the screw A.
2. Remove the cap B, then remove the screw C.

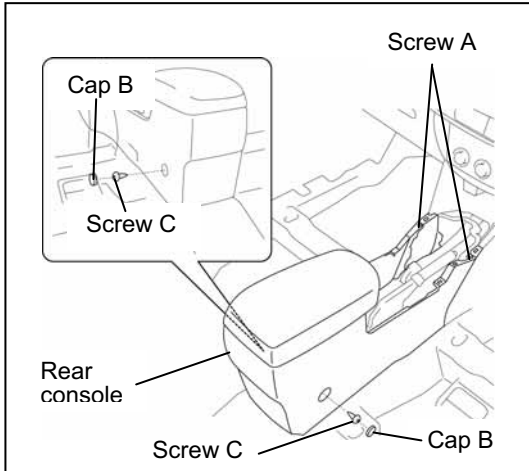

3. Pull the rear console in the direction of the arrow (1) while detaching the clip A.

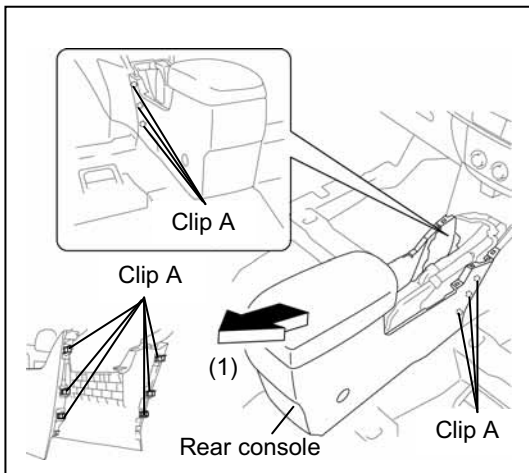

4. Remove the rear console in the direction of the arrow in the order of (2), (3), (4), (5) shown in the figure.

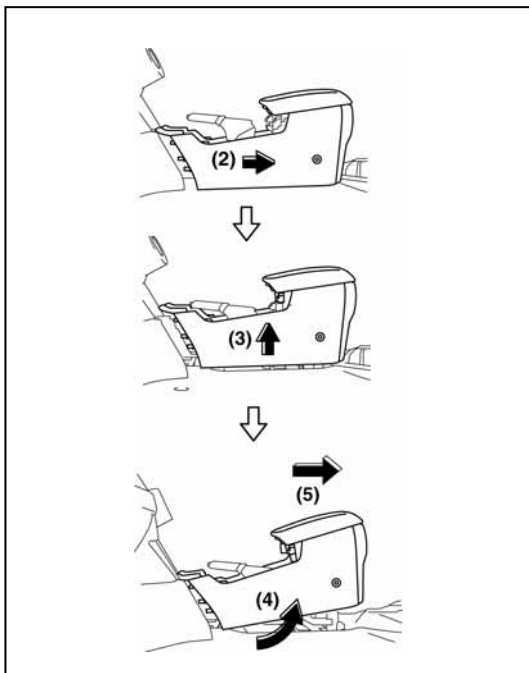

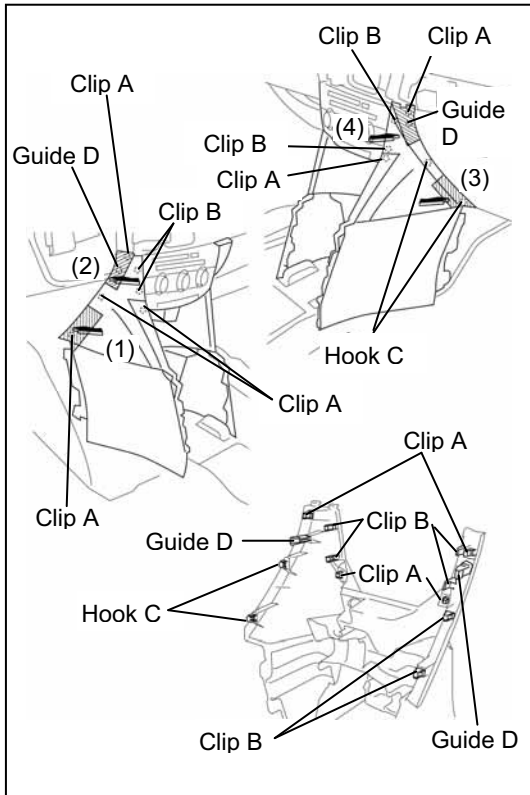

Front console removal

⚠ CAUTION

- Affix protective tape to the position shown in the figure.

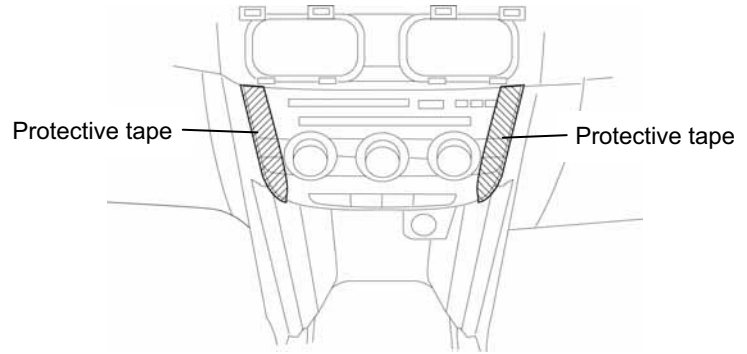

1. Take the shaded area shown in the figure, and remove the front console in the direction of the arrow in the order of (1), (2), (3), (4) while detaching the clip A, clip B, hook C, guide D.
2. Pull the front console in the direction of the arrow in the order of (5), (6) and remove the front console while detaching the shift lever (MTX) or selector lever (ATX)

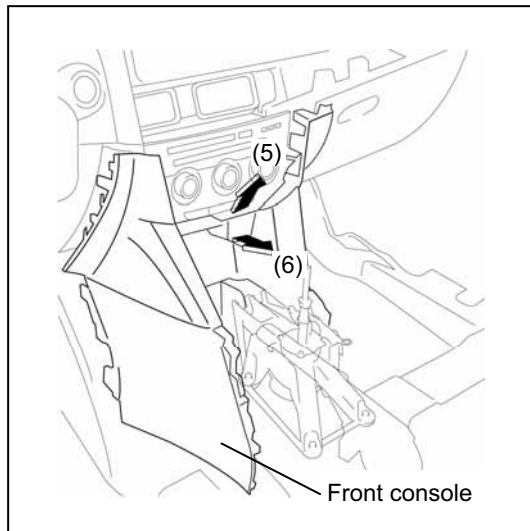

4. ACCESSORY SOCKET REMOVAL

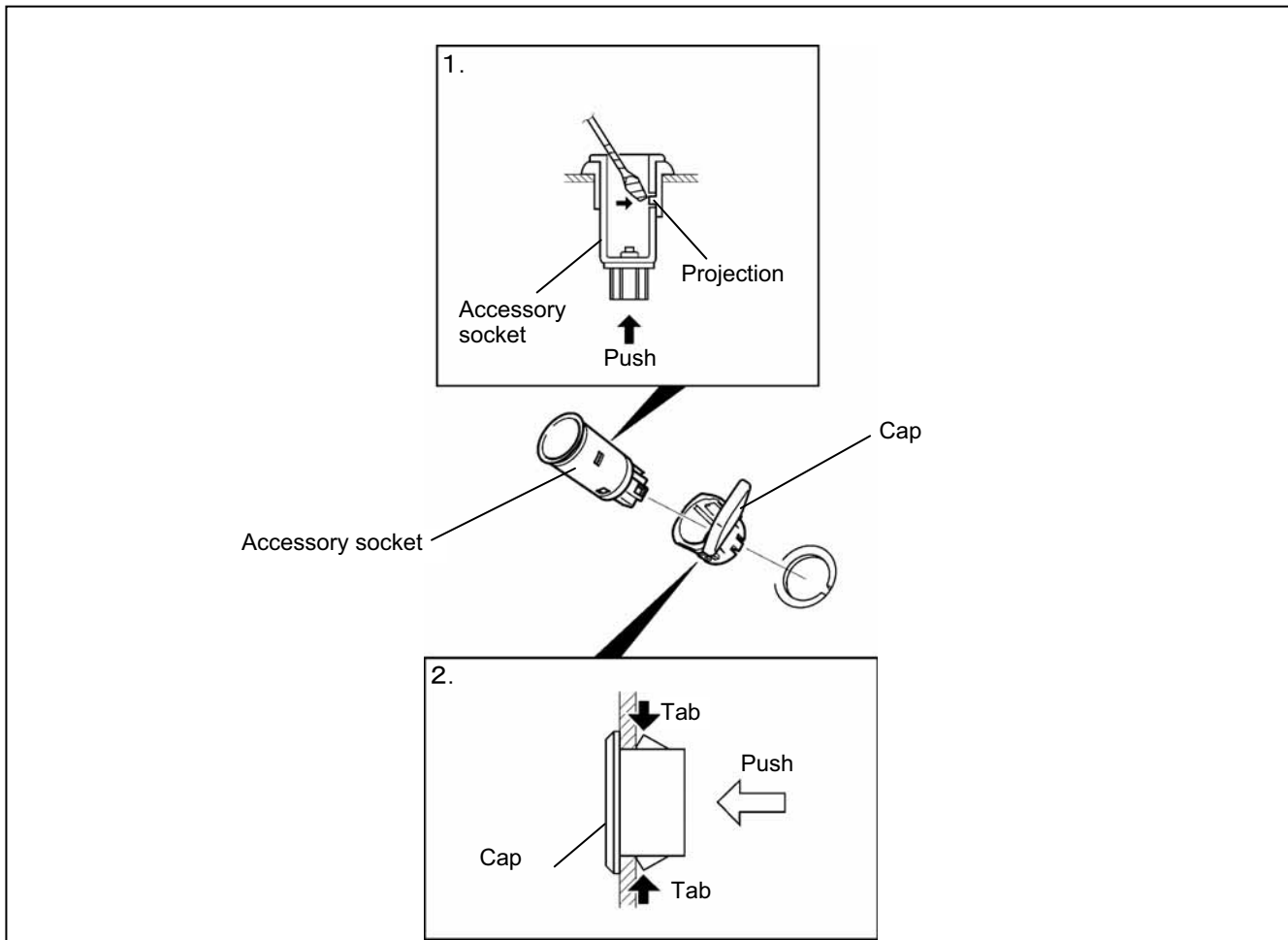

1. While pressing a tape-wrapped flathead screwdriver against the cap projection, pull the accessory socket outward.
2. While pressing the tabs, pull the cap outward.

5. CIGARETTE LIGHTER INSTALLATION

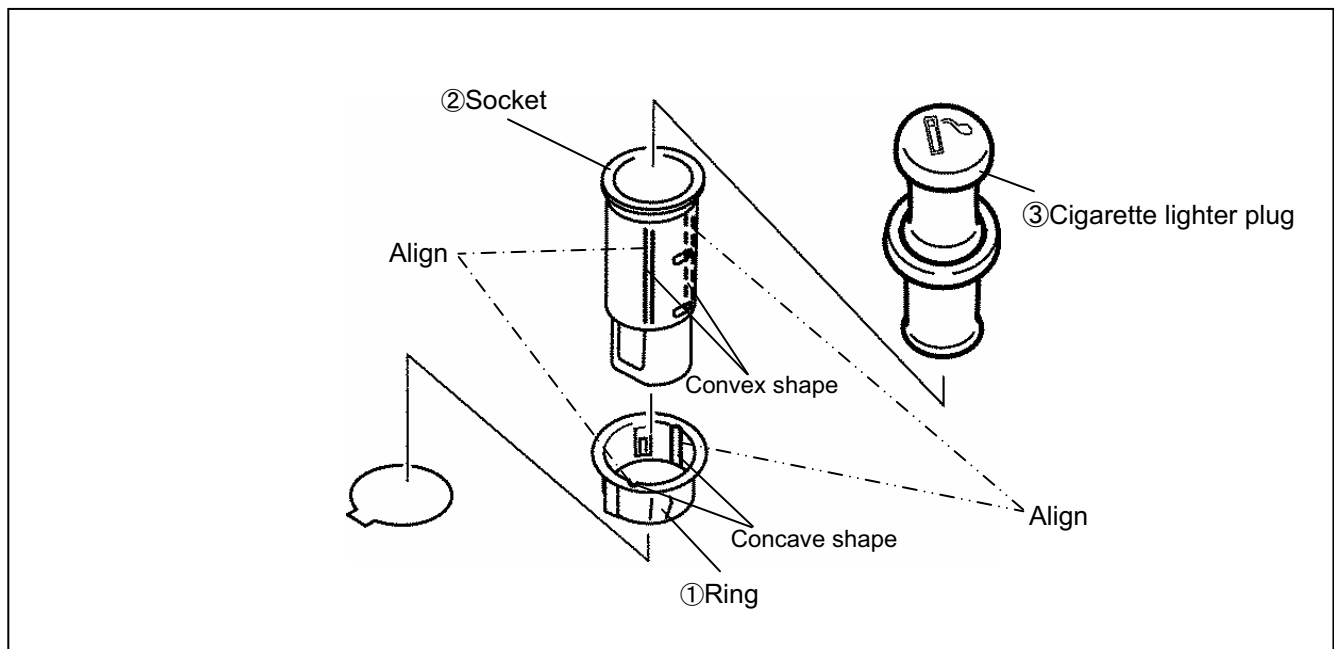

1. Align the ring with the contour of the front console panel and install it.
2. Align the ring and socket with the groove and install them.
3. Insert the cigarette lighter plug.
4. Install in the reverse order of the parts removal.
5. When installing the front console, connect the accessory socket connector.

6. OPERATION CHECK

1. Vehicle operation check

1. Connect the negative battery cable.

CAUTION

[i-stop system]

- When the negative battery cable for the main battery is disconnected, specific information stored in the PCM will be erased.
Perform the following procedure to resume operation:
 1. Switch the ignition off and disconnect the negative battery terminal and current sensor connector.
 2. Wait for 10 s or more after installing the negative battery terminal.
 3. Connect the current sensor connector and wait for 15 s or more (within 1 min) after the ignition is switched ON.
 4. Press and hold the i-stop OFF switch until i-stop light changes from illumination (amber) to flashing (green or amber) (for approx. 10 s).
 5. When i-stop light changes to flashing (green or amber), the ignition is switched off.
 6. Close the hood.
 7. Long press the i-stop OFF switch for 3 s within 5 s from switching the ignition ON.
 8. Switch the ignition on, and start the engine.
 9. Press the i-stop OFF switch to verify that the i-stop indicator light (green) flashes.
 - If the i-stop indicator light (green) does not flash, perform the operation from Step 7 again.
 10. Idle the engine until the i-stop indicator light (green) turns off.
 - Perform this procedure without an electrical load.
 11. Switch the ignition off, and start the engine.
If the function does not operate even after the ignition switch is turned off, contact an Authorized Mazda Dealer.

[Power window auto function]

- If the battery is disconnected, the automatic full open/close feature of the power window is disabled.
This feature can be recovered by the following procedure.
* For the power window with the automatic function, perform the all the initial settings.
 1. Turn the ignition switch to the ON position.
 2. Hold down the power window switch until the window is fully open.
 3. Pull up the power window switch to close the window and continue to pull it up for about two seconds after it is fully closed.
 4. If the feature does not function even after the ignition switch is turned off, contact an Authorized Mazda Dealer.

[TPMS system]

- If the battery is disconnected, the TPMS (Tire Pressure Monitoring System) initial setting is reset and the system may not operate normally.
This feature can be recovered by the following procedure.
 1. Adjust the tire pressure (verify tire pressure using label on body side with driver's door open).
 2. Turn the ignition switch to the ON position.
 3. Press the TPMS (SET) switch (long-press it until TPMS warning light in meter flashes two times and a beep sounds one time).
 4. Switch the ignition off.
 5. If the TPMS warning light illuminates or flashes even though the above procedure has been performed, contact an Authorized Mazda Dealer.

2. Cigarette lighter operation check

1. Turn the ignition switch to the ACC position.
2. Verify that the cigarette lighter comes out within **10—20 seconds**, after pressing the cigarette lighter plug into the socket.

7. USER'S INSTRUCTIONS

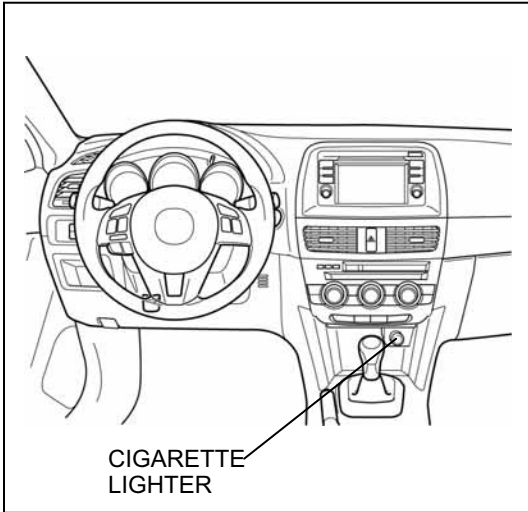

1. The ignition switch must be in the ACC or ON position.
2. Press the cigarette lighter in and release it.
3. When ready for use, it automatically pops out.

⚠ CAUTION

- Don't touch the metal part of the cigarette lighter, you burn yourself.
- Don't hold the cigarette lighter in because it will overheat.
- Don't use the cigarette lighter socket for plug-in accessories such as shavers and coffee pots. They may damage it or cause electrical failure. Use only a genuine Mazda cigarette lighter or the equivalent.
- If the cigarette lighter doesn't pop out within 30 seconds, remove it to prevent overheating.

INSTALLATION INSPECTION SHEET

**MAZDA
CX-5**

**CIGARETTE
LIGHTER**

BBP3 66 250

Inspection after installation

- Inspect the installed / reinstalled parts for the following items.

Inspection Parts	Check Item (○)			
	Clearance/Fit	Scratches/ Dirt/ Harness interference	Installation/ Tightening/ Engagement	Operation check
Cigarette lighter	○	○	○	○
Auxiliary jack (if equipped)		○	○	○
Power outlet		○	○	○
Command switch (if equipped)		○	○	○
Front console	○	○	○	
Side wall	○	○	○	
Rear console	○	○	○	
Upper panel	○	○	○	
Shift panel	○	○	○	
Decoration panel	○	○	○	
Negative battery cable	○	○	○	
Windows fully open and close automatically				○
TPMS				○

Installation inspection sheet for Cigarette lighter

Date _____, _____, _____					
VIN. _____					
Approved		Checked		Person in charge	